

Programmable Resistance - Capacitance - Inductance - RTD Decade Substituter

PRS-PCS-PLS-PRTD Series

Page 1 of 5

Broad range of programmable laboratory grade decade substituters for applications requiring a cost-effective, computer-controlled decade resistance, capacitance and/or inductance box. Manual control via front panel and computer control via RS-232, Ethernet or IEEE-488.2.



PRS Programmable Resistance Substituter with -D Digital Display and -RM rack mount options

Features:

All Substituters

- Manual control via thumbwheel switches standard
- Optional RS-232, Ethernet or IEEE-488 Interfaces
- 1 to 10 Decades
- Benchtop or rack mount versions
- Single or dual (two substituters in one chassis) versions
- Built to order so completely configurable at no added cost
- Special and high power versions available, contact IET Labs. with your requirements.

RESISTANCE - RTD

PRS - Programmable Resistance Substituter

The PRS Series of programmable resistance substituters is a cost-effective solution for a computer-controlled decade box. Ideal for both laboratory and industrial applications requiring highly reliable and automated switching of resistance.

Features

- Resistance from 1 m Ω /step to 10 M Ω /step
- Accuracy: $\pm(0.01\% + 15 \text{ m}\Omega)$ to $\pm(1\% + 70 \text{ m}\Omega)$
- Manganin wire for resistance values $< 1 \Omega$ /step
- Precision metal film resistors for PRS-200 and PRS-201 for 1 Ω /step and over
- Sealed wirewound non-inductive resistors for PRS-202 for 1 Ω /step to 100 k Ω /step
- Precision metal oxide film resistors for 1 M Ω and higher steps for PRS-202

PRTD - Programmable RTD Simulator

- Absolute reading, no "zero" resistance correction required
- Resistance from 4 Ω to 1000 Ω /step
- Resolution: 0.001 Ω

CAPACITANCE

- Accuracy: $\pm(0.02\% + 10 \text{ m}\Omega)$

PCS - Programmable Capacitance Substituter

The PCS Series of programmable capacitance substituters is ideal for both laboratory and industrial applications requiring highly reliable and automated switching of capacitance.

Features

- Capacitance from 100 pF to 10 μF /step
- Accuracy: $\pm(0.5\% + 3 \text{ pF})$ to $\pm(4\% + 3 \text{ pF})$
- 100 pF to 100 nF/Step decades utilize mica capacitors

INDUCTANCE

PLS - Programmable Inductance Substituter

The PLS Series of programmable inductance substituters is ideal for both laboratory and industrial applications requiring highly reliable and automated switching of capacitance. The PLS is similar to the IET 1492 Decade Inductor.

Features

- Inductance from 1 mH to 1H/step
- Accuracy: $\pm 2\%$



IET LABS, INC. in the **GenRad** Tradition
Long Island, NY

www.ietlabs.com
TEL: (516) 334-5959 • EMAIL: info@ietlabs.com

PRS Catalog March 2015

Programmable Resistance - Capacitance - Inductance - RTD Decade Substituter

PRS-PCS-PLS-PRTD Series

OPTIONS AND CONFIGURATIONS

Choice of Performance:

PRS-200 Series - economical 1% accuracy

PRS-201 Series - laboratory 0.1% accuracy

PRS-202 Series - high accuracy to 0.01% and improved stability using wire-wound resistors for 1 Ω /step to 100 k Ω /step for stability of 10 ppm/year. This compares to 50 ppm/year using precision metal film resistors in the PRS 200 and 201.



Model PRS-201 Bench Resistance Substituter

Wide choice of impedance ranges:

resistance, capacitance and inductance of up to 10 decades may be specified. Resistance may range from 1 m Ω to 100 M Ω .



Dual PRS Resistance and PCS Capacitance Substituter with rack mount option



PLS Programmable Inductance Substituter with digital display and rack mount options

Package Configuration: Convenient standard 19" rack mounting (RM) or more portable benchtop versions, are available. Both single and dual units are available.

Combinations: Dual units can combine any two resistance, capacitance, inductance substituters in one chassis.

Rear Outputs: Single or dual front panel binding posts are standard. Rear binding post outputs are available with option RO.

PRTD: Low-resistance models with a fixed minimum resistance setting (4 Ω or as specified by customer) are suitable for **RTD** (Resistance Temperature Detector) simulations. This design virtually eliminates the effect of zero resistance and relay contact resistance, providing the specified absolute accuracy over its entire range.

Digital Display (D Option): Shows the remotely programmed or manually set value. This is useful for confirming or monitoring the selected command value, remote or local. This option requires the rack mount **RM** option.



-D Digital Display Option

Short-Circuit (SC) and Open-Circuit (OC) Options: Optional short-circuit and open-circuit modes of operation. These states are controlled only in the **REMOTE** programming mode.

The Open Circuit OC option gives the user an open circuit immediately in series with the **HI** binding post during switching between values. The **Short Circuit SC** operation gives the user a short circuit across the **HI** and the **LO** binding posts during switching. The short circuit impedance is very small, <20 m Ω , typically 5 m Ω . This is lower than the regular zero resistance setting. In both these cases, the underlying resistance setting is unaffected and may still be controlled.

Special Customer Requirements: High voltage, nonstandard values, high stability, ultra-low temperature coefficient or improved accuracy can be accommodated.

High-Power Options: Power dissipation requirements of up to 500 Watts can be accommodated.



REMOTE CONTROL AND PROGRAMMING

Remote Control Options:

IEEE-488: GPIB interface features *IDN? and cal date query, allowing you to improve your instrument and calibration tracking capabilities. GPIB addressing is controlled via DIP switches or commands on the GPIB bus.

RS232: This interface conforms to EIA-STD-RS-530; with a 25 pin DTE interface.

The PRS is a standard DTE device in RS232 mode. Connection to a PC is made via a null-modem cable.

Ethernet: This interface conforms to IEEE 802.3

When equipped with any remote con-

trol functionality, the PRS front panel switch determines if **REMOTE** mode is *enabled*. Regardless of remote control type, setting the front panel switch to the **LOCAL** position *always* disables the remote control "set" value.

Supported commands include: *IDN?, *CLS, *ESE?, *ESR?, *IDN?, *RCL, *RST, *SAV, *STB?, SYST: ERR?, CAL:DATE? and SOURce:DATA <VAL-UE>

The remote output value is set by sending a 'SOURce:DATA' command followed by a string that represents the digits as they would be selected using the thumbwheels. Leading and trailing zeros are required to set each decade properly; the decimal point is not used.

For example; the PRS-202-IEEE has a least significant digit value of 1 m Ω and a remote logic maximum of 12 command decades. To set a value of 50,000.045 Ω , the command string would be:

SOURce:DATA 000050000045

The PRS-201 & PRS-202 RS-232 has a least significant digit value of 0.1 Ω and a remote logic maximum of 10 command decades. To set a value of 2,500.8 Ω , the command string would be:

SOURce:DATA 000025008

LABVIEW DRIVERS AND SOFTWARE

LabVIEW instrument drivers are available for units equipped with GPIB or RS232C options. These drivers are written based on the National Instruments instrument template, using VISA handles and standard initialize, configure and query functions.

To aid the user in operating the PRS/PCS/PLS, two "Keyboard" Controller programs - the easiest way to control GPIB or RS232 devices without writing a program - are available from IET. This Keyboard programs automatically finds your device at start-up and it lets

you enter just the data that you want to send to the device. This program works with ICS and National Instruments GPIB cards.

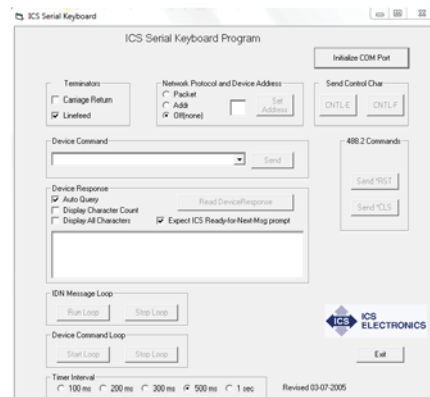
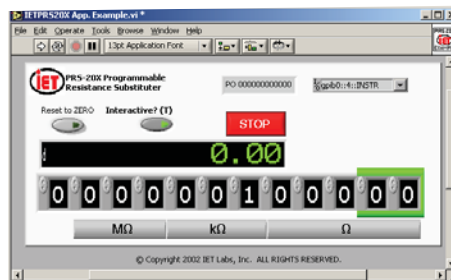
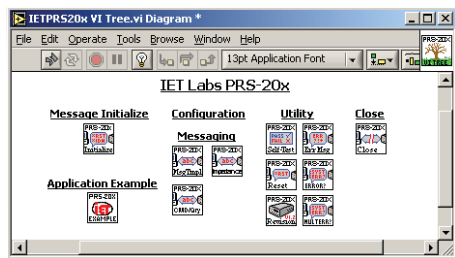

Programmable Resistance - Capacitance - Inductance - RTD Decade Substituter

PRS-PCS-PLS-PRTD Series

SPECIFICATIONS

User interface: Front panel switch selects **REMOTE** (Optional: IEEE-488 , Ethernet or RS-232 interface) or **LOCAL** (front-panel thumbwheel) operation.

Accuracy: The accuracy shown in the chart below applies after subtraction of the "zero setting" residual impedance.

Accuracy (PRTD): The absolute accuracy indicated below applies without requiring subtraction of "zero setting" residual impedance.

Min. setting (PRTD): 4 Ω or customer specified.

Thermal emf: < 15 μV; < 10 μV, typical.

Terminals:

Four low-emf, gold-plated, tellurium-copper 5-way binding posts are used for **HI** and **LO** terminal pairs for **CURRENT** and **SENSE**. **GND** binding post is connected to the case, to the chassis ground and to the earth ground. Rear outputs are available with the **RO** option.

Switching time: <4 ms per change; <7 ms for ≤0.05% units.

Power requirements: 90 - 264 Vac , 47 - 63 Hz. 30 Watts Max.

Dimensions: Bench model: 22 cm W x 12 cm H x 24 cm D (8.5" x 4.44" x 9.25") Rack model: *Panel:* 48.3 cm W x 13.2 cm H (19" x 5.2"); *behind panel:* 42.7 cm W x 12.4 cm H x 31.5 cm D (16.8" x 5.2" x 12.4"); *in front of panel:* 3.8 cm (1.5").

Weight: Bench model: 2.0 kg (4.5 lb); Rack model: 4.5 kg (10 lb); Dual rack mount model: 6.4 kg (14 lb); weight specifications are nominal.

Remote Control Options:

IEEE: GPIB standard 24 pin connector, conforms to IEEE-488.2; SCPI 1994.0 command set; Hardware or software configurable addressing range of 0 to 30.

RS232: 25 pin male DTE interface conforms to EIA-STD-RS-530; SCPI 1994.0 command set; data rates from 300 to 115200 bps.

Ethernet: IEEE 802.3 compliant, Speeds 10 BaseT (10 Mb/s) and 100 BaseT (100 Mb/s), IP Address Static or DHCP, Factory setting 192.168.0.254 static

Model	PRS-200	PRS-201	PRS-200W	PRS-201W	PRS-202	PRS-202W	PRTD	PCS-300	PCS-301	PLS-400	PLS400A
Type	Resistance	Precision Resistance	Wide-Range Resistance	Wide-Range Precision Resistance	High-Precision Resistance	Wide-Range High-Precision Resistance	Precision Absolute-Value Resistance	Precision Capacitance	Wide-Range Capacitance	Wide-Range Inductance	Inductance
Accuracy	1% +70 mΩ	0.1%+ 30 mΩ	1%+ 70 mΩ	0.1%+ 30 mΩ	0.05% + 15 mΩ (0.01% optional)		.05% + 10 mΩ	4% + 5 pF	1% + 3 pF	2%	
Decades	7		9		7	9	6 or more	6		4	3
Range	0 - 9,999,999 Ω		0 - 99,999,999.9 Ω		0 - 9,999,999 Ω	0 - 99,999,999.9 Ω	4-10,003.99 Ω	0 - 99.999 9 μF		0 - 9.999 H	0 - 999 mH
Resolution	1 Ω		0.1 Ω		1 Ω	0.1 Ω	0.01 or 0.001 Ω	100 pF		1 mH	
Type of Components	Resistance wire for 0.1 Ω steps and under Precision metal film for 1 Ω steps and over				Resistance wire for 0.1 Ω steps and under Wirewound, sealed non-inductive resistors for 1 Ω to 100 kΩ steps *; Precision metal-oxide film resistors for 1 MΩ steps and over			100-900 pF: Mica 0.001-0.009 μF: Polystyrene 0.01-0.9 μF: Polycarbonate 1-9 μF: Polyester 10-90 μF: Polarized tantalum		Toroidal inductors See inductance Substituters for specifications	
Max. Load*	0.5 A, 200 V (dc + ac peak), 0.2 W/step, 2 W unit, whichever applies first.				3 A, 200 V (dc + ac peak), 0.5 W/step, 4.5 W/unit, whichever applies first.			100 V (20 V for 10-100 μF)			
Residual Impedance	<450 mΩ		<600 mΩ		<100 mΩ	<140 mΩ typ. <100 mΩ	Absolute Value	7 pF, typ. higher with Rear Output		<50 μH	

* PRS with accuracy of 0.1% to 4% use precision metal film resistors for 1 Ω steps and over



Programmable Resistance - Capacitance - Inductance - RTD Decade Substituter

PRS-PCS-PLS-PRTD Series

ORDERING INFORMATION

STANDARD MODELS

PRS-200	Programmable Resistance Substituter
PRS-201	Programmable Precision Resistance Substituter
PRS-200W	Programmable Wide-Range Resistance Substituter
PRS-201W	Programmable Wide-Range Precision Resistance Substituter
PRS-202	Programmable High-Precision Resistance Substituter
PRS-202W	Programmable Wide-Range, High-Precision, Resistance Substituter
PCS-300	Programmable Capacitance Substituter
PCS-301	Programmable Precision Capacitance Substituter
PLS-400	Programmable Wide-Range Inductance Substituter
PLS-400A	Programmable Inductance Substituter
PRTD Models	Programmable RTD Simulator

OTHER OPTIONS

RM Option	Rack mount
RMK Option	Rack mount Kit
RO Option	Rear output
D Option	Digital display of programmed value
SC Option	Short circuit option
OC Option	Open circuit option
HP	Custom high power specifications

GPIO CABLES

CBL-488-1	1 meter IEEE-488 cable
------------------	------------------------

INTERFACE OPTIONS

IEEE Option	IEEE-488.2 Interface
RS232 Option	Serial interface
Ethernet Option	Ethernet IEEE 802.3

CONFIGURATION

In order to satisfy any unique requirements for programmable substituters, generate a part number from the table below.

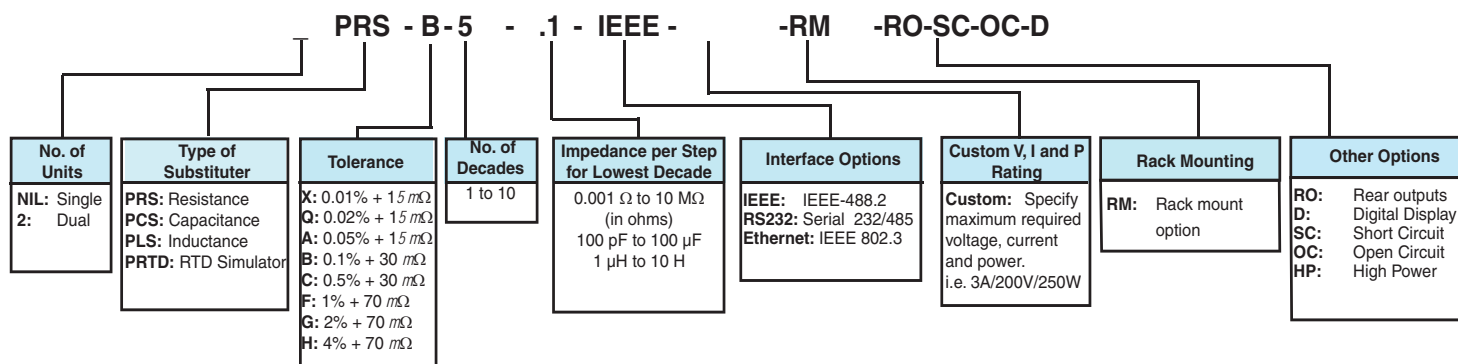

(i.e.: 0 - 9,999.9 Ω, 0.1%, 5 decades, 0.1 Ω steps, rack mounted PRS with IEEE-488 remote control, rear outputs, short circuit and open circuit operation, and digital display)

