

- Ideal for CMTI testing of optocouplers, optoisolators, and isolated gate drivers
- Linear rise to ± 1 , ± 1.5 , or ± 2 kV

- Transition times down to 10 ns, rates up to 120 kV/us
- Includes IEEE-488.2 GPIB, RS-232 ports
- Ethernet port for VXI-11.3 support

The AVRQ series is suitable for generating the high-speed, high-voltage waveforms necessary for transient immunity testing of opto-couplers and other semiconductor devices.

The AVRQ-4-B is specifically designed for optocoupler testing, and offers four pulse amplitudes (-1.5kV, -1kV, +1kV and +1.5 kV), with the transition time (10%-90%) of the leading edge variable from less than 20 ns to more than 500 ns (at 1.5 kV). At its highest amplitude and fastest transition time, the AVRQ-4-B provides transition rates of $1.5 \text{ kV} \times (90\% - 10\%) / 20 \text{ ns} = 60 \text{ kV/us}$.

The AVRQ-4-B provides a daughterboard arrangement for the user's opto-couplers. The high-voltage pulse is applied between the floating ground on the input side (GND1) and the chassis-ground on the output side (GND2). The ground-referenced output-side power (VCC2) is adjustable (+3V to +8V, or to +43V with the -SCHB option), but the floating input-side power (VCC1) is not provided by the mainframe. Instead, an A23-style 12V battery should be installed on the DUT daughterboard to provide an isolated floating power source, along with a basic low-dropout regulator circuit to provide the necessary regulated power (VCC1). Sample daughterboards suitable for testing typical 5V DIP8 devices are included.

The AVRQ-4-B provides a pattern of pin sockets into which a daughterboard may be plugged. Several daughterboards are included with each AVRQ-4-B, to accommodate common test configurations for common 8-pin DIP voltage-drive and current-drive optocouplers. The logic inputs on voltage-drive opto-couplers are jumpered to VCC1 or GND1, as appropriate. For current-drive optocouplers, the LED anode is connected to GND1 directly or to VCC1 through a series resistor. The output side of the daughterboard includes provision for installing a pull-up resistor to VCC2, if required. To perform tests with different logic-level inputs or values of pull-up resistance, different daughterboards must be plugged in. Jumpers are provided to configure the daughterboards for single or dual-channel pinouts.

The high-voltage pulse and the opto-coupler logic output of the AVRQ-4-B are accessible for measurement with high-impedance probes.

The AVRQ-5-B is similar, but achieves faster switching speeds by making some trade-offs with convenience. The

standard model offers two amplitude settings (-1.5 kV and +1.5 kV). The unloaded switching time is fixed at $\leq 10 \text{ ns}$, 10%-90%. The transition time may be increased up to 50 ns by adding high-voltage capacitors across the device under test (by soldering it to the DUT daughterboard). This corresponds to transition rates of 24 – 120 kV/us. Unlike the AVRQ-4-B, the transition time is not controlled from the front panel.

For both the AVRQ-4-B and AVRQ-5-B, the -AHV option provides greater flexibility in the amplitude setting, permitting adjustment from 1.0 to 1.5 kV (+ or -) in $\leq 1\text{V}$ steps.

The -XHV option provides a higher amplitude range of 1.5 to 2.0 kV (+ or -) in $\leq 1\text{V}$ steps, but the minimum switching time increases by 5 ns.

The DUT daughterboard socket area is normally located behind a safety door on the rear panel. The DUT area may optionally be moved to the front panel of the AVRQ-4-B or AVRQ-5-B by specifying the -FPD option. This is more convenient for the user, but it increases the height of the instrument from 3U to 5U (in rack units) and higher shipping costs may apply. An ATA-style shipping case is required for the taller units for safe shipping.

CAM files for the AVRQ-4-B and AVRQ-5-B sample daughterboards are available for download from the Avtech web site, so that users may modify the designs to accommodate other package styles. It may be necessary to solder the DUTs directly to the PCB, rather than using a socket. Sockets may introduce unhelpful pin-to-pin signal coupling that can noticeably degrade the measured CMTI performance, particularly for small-pitch devices.

Units with serial numbers of 13700 and below used a different socketing and daughterboard arrangement. Later units have a different arrangement that offers lower parasitic inductance. Contact Avtech if you are interested in an upgrade. With the current socketing design, the same daughterboards may be used in the AVRQ-4-B and the AVRQ-5-B.

For all models, the high voltage pulse starts to decay back to zero approximately 1-20 microseconds (adjustable) after the start of the leading transition. The fall time of this decay is at least ten times greater than the rise time of the leading edge. The pulse repetition frequency is adjustable

from 1 Hz to 10 Hz, using the front panel controls or by computer command. This instrument may also be triggered by an external TTL trigger pulse (10 Hz maximum), by a computer command, or by a front-panel pushbutton.

On all models, the output will “time-out” after 90 seconds of command inactivity. After that time, the output will be disabled. The output must be re-enabled from the front panel or by computer command for the next test.

A delay control and a sync output are provided for oscilloscope triggering purposes. The sync output (a BNC connector located on front panel) provides a TTL pulse with 100 ns pulse width, and will drive 50 Ohms. The delay between the main output and the sync output is variable from 0 to 1.0 seconds.

These models require a high-impedance load. They will not operate correctly into lower resistances, or into loads with more than the rated capacitance (including the cabling and oscilloscope probe capacitance). The rise time is NOT a calibrated value due to the influence of the load capacitance – it must be measured with an appropriate high-voltage oscilloscope probe system.

All models include a complete computer control interface

(see <http://www.avtechpulse.com/gpib> for details). This provides GPIB and RS-232 computer-control, as well as front panel keypad and adjust knob control of the output pulse parameters. A large back-lit LCD displays the output amplitude, frequency, pulse width, and delay. To allow easy integration into automated test systems, the programming command set is based on the SCPI standard, and LabView drivers are available at <http://www.avtechpulse.com/labview>.

A standard rear-panel Ethernet connector allows the instrument to be remotely controlled using the VXI-11.3, ssh, telnet, and web protocols. In particular, the VXI-11.3 features allows software like LabView to control an instrument using standard VISA communications drivers and network cabling, instead of using older-style GPIB cabling and GPIB controller cards. See <http://www.avtechpulse.com/options/vxi> for details.

Extensive test results, and details of the daughterboard arrangement used in the AVRQ-4-B and AVRQ-5-B are provided in the operating manuals at:

<http://www.avtechpulse.com/cmti/avrq-4/#manuals>
<http://www.avtechpulse.com/cmti/avrq-5/#manuals>



AVRQ-4-B FRONT PANEL

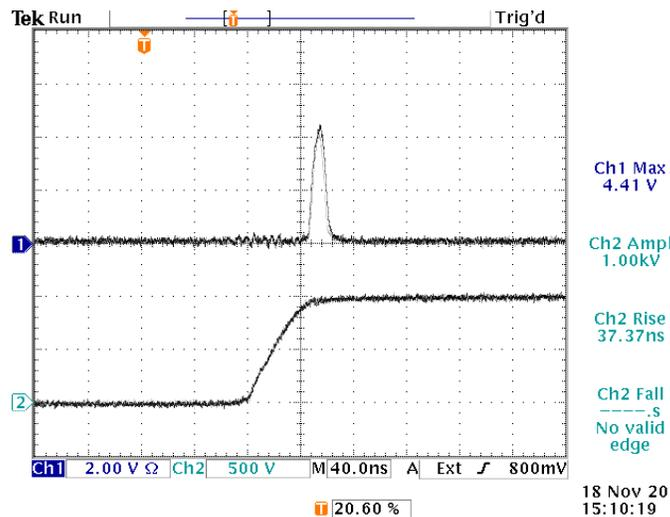

Top: Logic output of an optocoupler installed in the AVRQ-4-B, 2V/div, 40 ns/div. A transient glitch is observed.
 Bottom: +1 kV common-mode pulse with 37.37 ns transition time (10%-90%) applied across the optocoupler.



SPECIFICATIONS

AVRQ SERIES

Model:	AVRQ-4-B ¹	AVRQ-5-B ¹
High-Voltage Pulse Amplitude: (HV pulse / GND1)	Standard: -1.5, -1, +1, or +1.5 kV with -AHV ⁹ option: -1 kV to -1.5 kV, +1 kV to +1.5 kV, in $\leq 1V$ steps with -XHV ¹⁰ option: -1.5 kV to -2 kV, -1.5 kV to -2 kV, in $\leq 1V$ steps	Standard: -1.5 or +1.5 kV with -AHV ⁹ option: -1 kV to -1.5 kV, +1 kV to +1.5 kV, in $\leq 1V$ steps with -XHV ¹⁰ option: -1.5 kV to -2 kV, -1.5 kV to -2 kV, in $\leq 1V$ steps
Load resistance:	> 10 Megohms (this is not a 50 Ohm system.)	
Load capacitance (C_{LOAD}):	< 15 pF total, including DUT capacitance and probes (can tolerate up to 300 pF, but the switching times will degrade significantly).	0 to ~ 300 pF. Must be adjusted to obtained the desired transition time.
Load connection style:	A pattern of pin sockets into which a daughterboard may be plugged is provided. Sample daughterboards with 8-pin DIP sockets are included. The user may also use their own custom-made daughterboards.	
Leading edge rise time for maximum output voltage ² (10% - 90%):	< 20 ns ¹² (< 25 ns with -XHV option ^{10,12}) up to > 500 ns, adjustable using front-panel settings or computer command.	≤ 10 ns ¹² (≤ 15 ns with -XHV option ^{10,12}) for $C_{LOAD} = 0$. Up to 50 ns, by increasing C_{LOAD} .
Leading edge shape:	Approximately linear. See the typical waveform photos on the preceding and following pages.	
Trailing edge fall time ³ (90%-10%):	At least ten times greater than the leading edge rise time. Not adjustable.	
Trailing edge shape:	Exponential decay, approximately. See the typical waveform photos on the preceding and following pages.	
Pulse width (measured between the start of the leading edge and the start of the falling edge):	1 - 20 μ s, adjustable.	
PRF:	Standard: 10 Hz maximum -HF option: 100 Hz maximum	
VCC1 power supply (input side, floating, referenced to HV pulse / GND1):	Not provided by the mainframe. The input side of the daughterboards must be self-powered. The included sample boards use an A23-type battery with a low-dropout regulator.	
VCC2 power supply ¹¹ (output side, referenced to GND2 chassis ground):	Standard: +3 to +8V, adjustable, 150 mA maximum Optional ⁷ : +3 to +43V, adjustable, 150 mA maximum	+3V to +43V, adjustable 150 mA maximum
Logic output pull-up resistance:	User-installed, on daughterboard as appropriate	
Output connector, HV PULSE:	BNC female, suitable for use with the Tektronix P5100 high-voltage probe and 013-0291-00 probe-tip-to-BNC adapter. Other probes may be suitable. Not intended to drive any length of coaxial cabling directly.	
Output connector, logic output:	A two-pin header suitable for use with the Tektronix P6246 differential probe ⁸ . Other probes may be used by installing a matching two-pin socket as an extender.	
Output enable timer:	The output will only remain active for 90 seconds after the last output parameter update. After that time, the output will be disabled. The output must be re-enabled from the front panel or by computer command for the next test sequence.	
Propagation delay:	≤ 200 ns (Ext trig in to start of output pulse)	
Jitter (Ext trig in to pulse out):	± 200 ps $\pm 0.03\%$ of sync delay	
Trigger modes:	Internal trigger, external trigger (TTL level pulse, > 10 ns, 1 k Ω input impedance), front-panel "Single Pulse" pushbutton, or single pulse trigger via computer command.	
Variable delay:	Sync to Out: 0 to ± 1.0 seconds, for all trigger modes (including external trigger).	
Sync output:	+3 Volts, 100 ns, will drive 50 Ohm loads	
Gate input:	Synchronous, active high or low, switchable. Suppresses triggering when active.	
Other connectors:	Trig, Sync, Gate: BNC	
GPIB and RS-232 control:	Yes. (Visit http://www.avtechpulse.com/labview for LabView drivers.)	
Ethernet port, for remote control using VXI-11.3, ssh, telnet, & web:	Optional ⁴ . Recommended as a modern alternative to GPIB / RS-232. See http://www.avtechpulse.com/options/vxi for details.	
Settings accuracy:	Not calibrated. Verify the output parameters with a calibrated oscilloscope.	
Power requirements:	100 - 240 Volts, 50 - 60 Hz	
Dimensions: (H x W x D)	145 x 430 x 475 mm (5.7" x 17" x 18.8")	
Chassis material:	cast aluminum frame and handles, blue vinyl on aluminum cover plates	
Temperature range:	$+5^{\circ}\text{C}$ to $+40^{\circ}\text{C}$	

- B suffix indicates IEEE-488.2 GPIB and RS-232 control of amplitude, pulse width, PRF and delay (See <http://www.avtechpulse.com/gpib/>).
- The rise time is affected by the load capacitance. A high-voltage high-bandwidth oscilloscope probe such as the Tektronix P5100 should always be used to verify the actual output rise time, rather than relying on the programmed value.
- Refers to the trailing edge, which swings from -1000V or -2000V to 0V
- Add the suffix -VXI to the model number to specify the Ethernet port.
- Note that coaxial cabling typically adds 30 pF/ft.
- The user must install a standard 9V battery in the provided holder, in order to power the floating power supply. The battery is not included, due to shipping regulations.
- To specify the extended VCC2 range, add the -SCHB option suffix to the model number.
- A differential probe is suggested to reduce the possibility of interference from the high-voltage pulse. Note that the P6246 is only suitable for values of VCC2 up to +7V. A non-differential probe may be more suitable if VCC2 $> 7V$, or if parasitic inductances or capacitances in the test circuit cause differential voltage spikes

- exceeding $\pm 7V$. The P6246 can saturate under those conditions, which can generate apparent glitch-like transients that are not due to the DUT. Some experimentation may be required by the user in order to identify the best probing arrangement.
- Add the suffix -AHV to the model number to specify the +/- 1 to 1.5 kV (in $\leq 1V$ steps) operating range.
- Add the suffix -XHV to the model number to specify the +/- 1.5 to 2 kV (in $\leq 1V$ steps) operating range. This option increases the minimum switching time by 5 ns.
- VCC2 is normally provided at the DUT socket. It can also be provided on a BNC connector for monitoring purposes by specifying the -V2 option. The BNC connector will be on the same panel as the DUT enclosure (rear panel for standard units, front panel for -FPD units.) The shield of this BNC connector is connected to GND2 / chassis ground.
- Valid with a Tektronix P5100 high-voltage probe connected directly to the HV PULSE connector. Connecting anything else (e.g., additional coaxial cabling or external DUTs) may degrade the switching times significantly.

DAUGHTERBOARD ARRANGEMENT FOR THE AVRQ-4-B AND AVRQ-5-B

The DUT area is located on the rear panel, behind a hinged door:

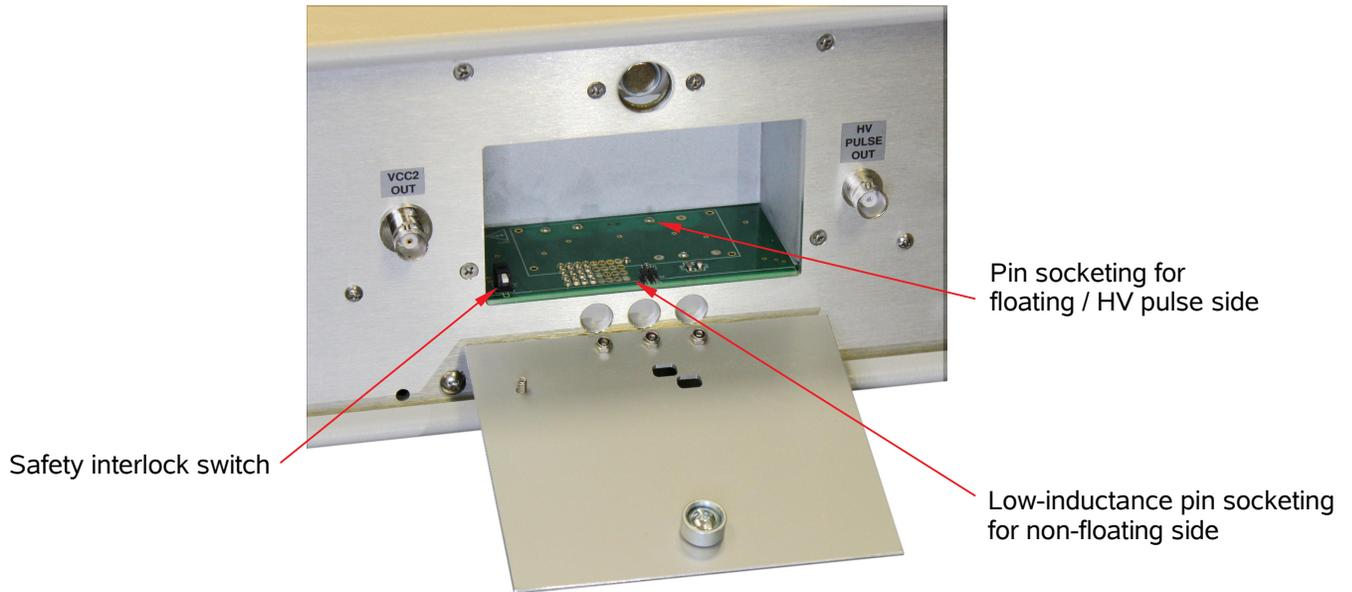

The outputs are automatically disabled when the DUT door is open (as sensed by the safety interlock switch).

A daughterboard is installed into the pin socketing on the main board, as shown below.

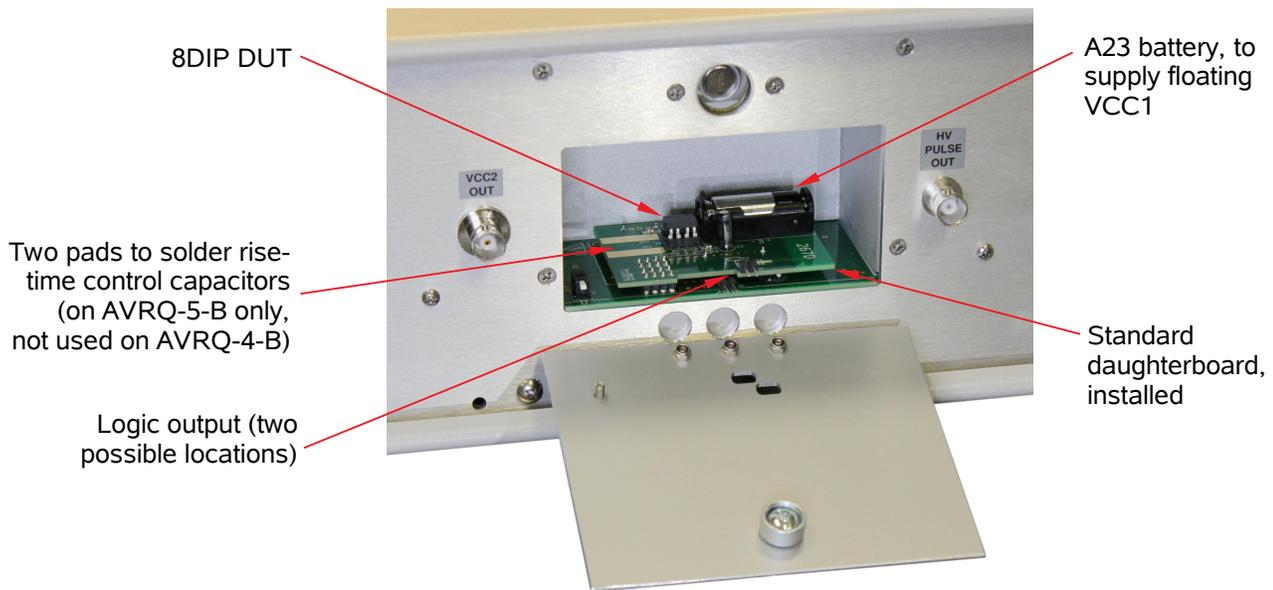

BASIC TEST ARRANGEMENT FOR THE AVRQ-4-B

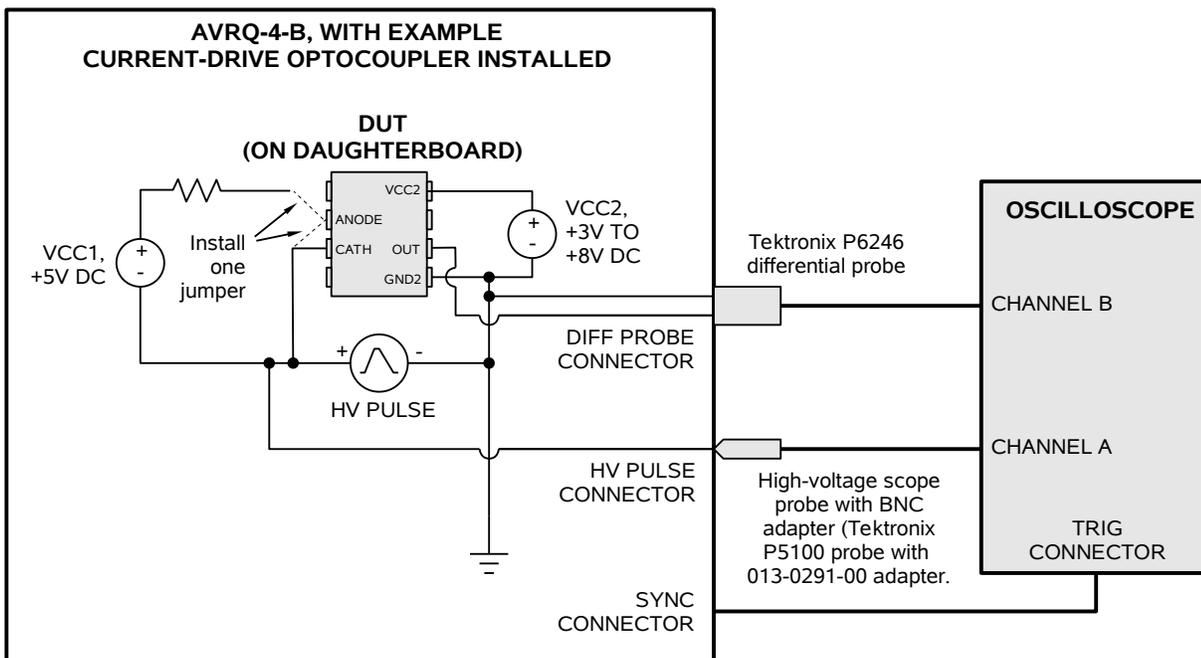
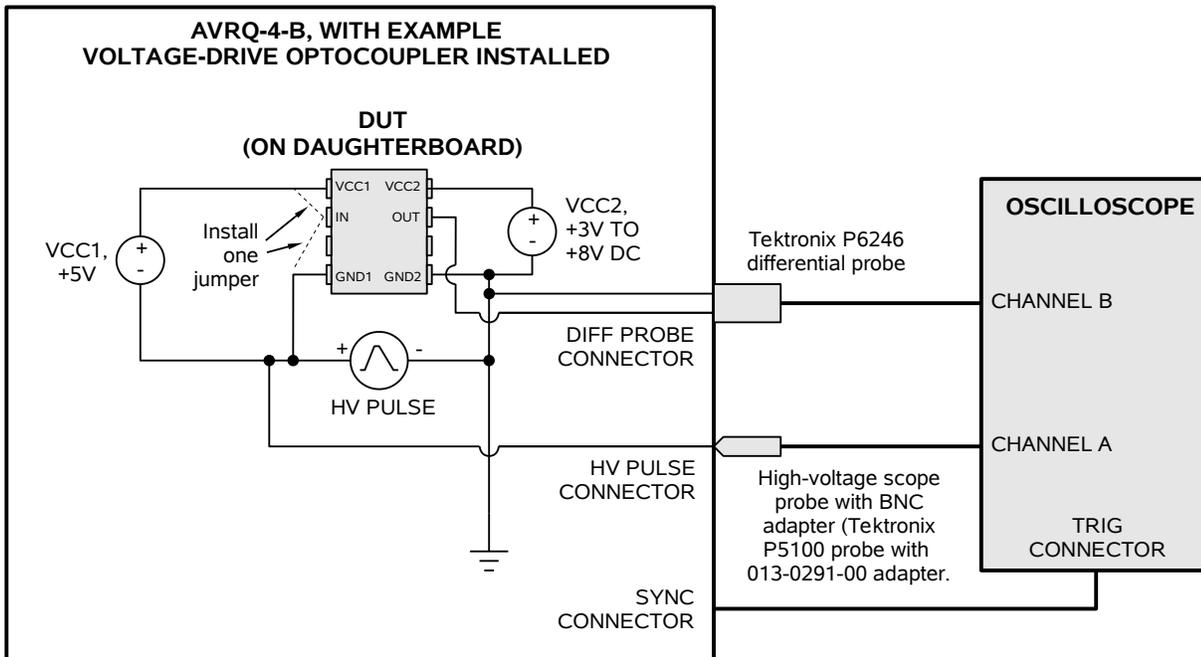

CUSTOMIZATIONS

The AVRQ-4-B and AVRQ-5-B may be customized to accept particular package types and pinouts, and to provided daughterboards configured appropriately for the required tests. Contact Avtech (info@avtechpulse.com) with your requirement.

TYPICAL WAVEFORMS FOR THE AVRQ-4-B

Testing CH A of an Avago HCPL-2630 dual-channel opto-coupler, with a -1 kV pulse, $V_{CC2} = +5V$, LED bias = +7.5 mA, and a pull-up resistance of 350 Ohms shows that a logic glitch starts to occur when the HV pulse transition time is 70.69 ns. The glitch increases in amplitude as the rise time decreases:

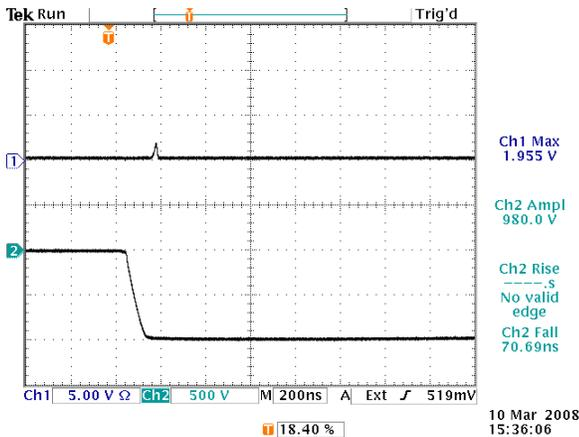

Top: HCPL-2630 logic output, 5V/div, 200 ns/div.
Bottom: -1 kV pulse with 70.69 ns transition time applied across the HCPL-2630 input/output sides.

The logic glitch is just starting. The estimated CMTI under these conditions is thus $1 \text{ kV} / (0.9 - 0.1) / 70.69 \text{ ns} = 17.7 \text{ kV/us}$. The manufacturer's specification is 5 kV/us.

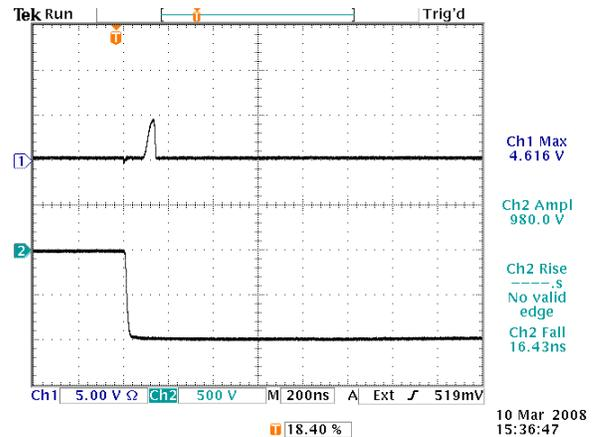

Top: HCPL-2630 logic output, 5V/div, 200 ns/div.
Bottom: -1 kV pulse with 16.43 ns transition time applied across the HCPL-2630 input/output sides.

The logic glitch has increased with the decreased HV pulse transition time.

Testing HCPL-2601 single-channel opto-couplers from two different manufacturers with a +1 kV pulse, $V_{CC2} = +5V$, LED bias = 0 mA, and a pull-up resistance of 350 Ohms shows a difference in performance:

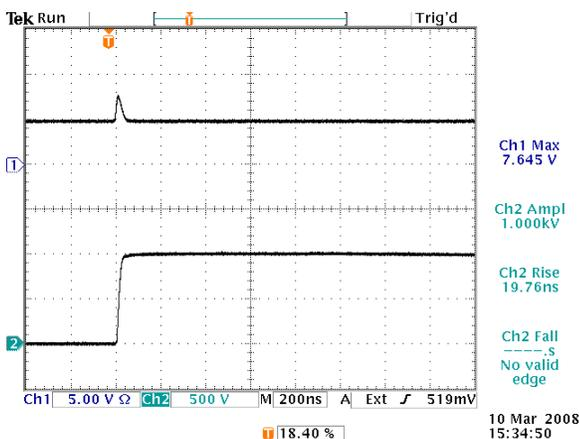

Top: Avago HCPL-2601 logic output, 5V/div.
Bottom: +1 kV pulse with 19.76 ns transition time applied across the HCPL-2601 input/output sides.

Some of the HV pulse capacitively couples to the logic output, causing a positive spike, but the logic state does not change. No glitch is observed. The CMTI thus exceeds $1 \text{ kV} / (0.9 - 0.1) / 19.76 \text{ ns} = 63.2 \text{ kV/us}$, which is the limit of this test system.

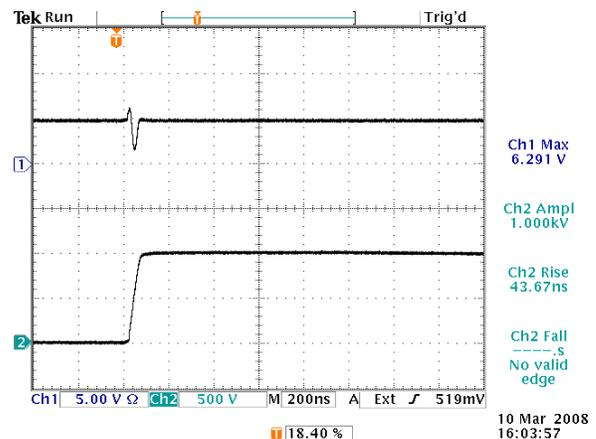

Top: QTC HCPL-2601 logic output, 5V/div.
Bottom: +1 kV pulse with 43.67 ns transition time applied across the HCPL-2601 input/output sides.

With this device, a negative-going glitch is observed. (It is not caused by capacitive coupling, since it is opposite in polarity to the HV pulse slope.) The observed CMTI is thus $1 \text{ kV} / (0.9 - 0.1) / 43.67 \text{ ns} = 28.6 \text{ kV/us}$.

TYPICAL WAVEFORMS FOR THE AVRQ-5-B

The AVRQ-5-B provides faster switching times than the AVRQ-4-B, with the switching time controlled by a user-installed capacitance. Typical positive and negative waveforms with 0 and 150 pF capacitances are shown below:

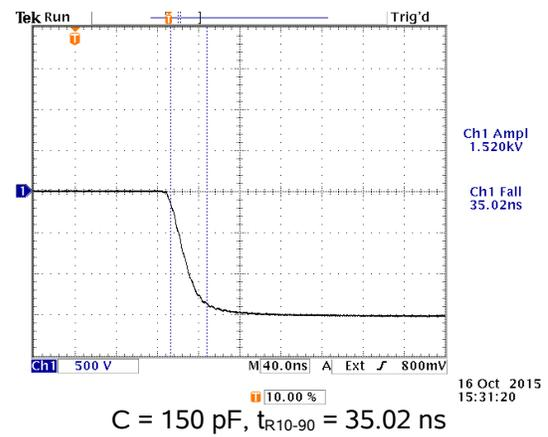
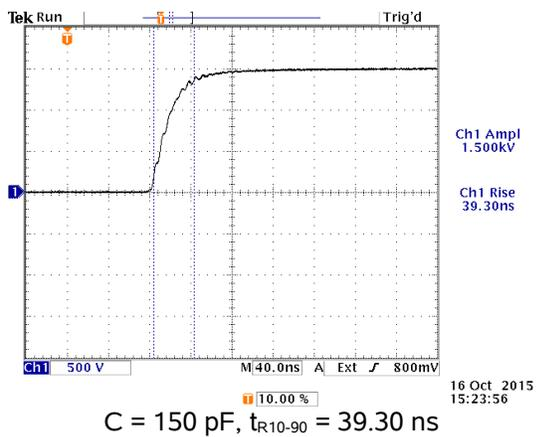
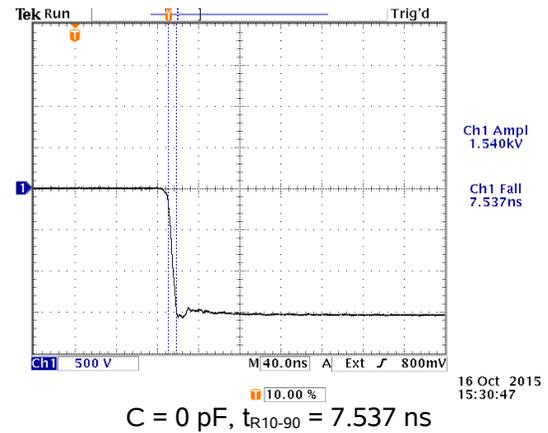
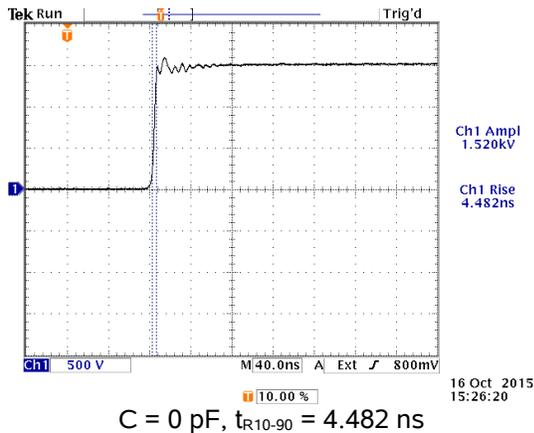

ALTERNATIVE MECHANICAL STYLE, -FPD OPTION

The AVRQ-4-B and AVRQ-5-B are normally provided in a 3U-rack-height chassis with the DUT area located on the rear panel. This provides the most compact use of space, but it is not necessarily convenient for the user. The DUT area may optionally be moved to the front panel of the by specifying the -FPD option. This increases the height of the instrument from 3U to 5U (in rack units) and higher shipping costs may apply. An ATA-style shipping case is required for the taller units. An example of an AVRQ-5-B-FPD is shown below:

